

### Level 1 Pre-course Geometry

Thank you for booking your place onto the ATTMA Level 1 course. In the course we will be using geometry to work out envelope areas manually, a key component to becoming an air tightness tester. This quick 'test' will help ensure that you have a solid foundation and can better understand and apply the concepts discussed during the course.

**Please note that this 'test' is optional, so there is no need to bring it with you on the day.**

1. What is the area of the rectangle?

Answer

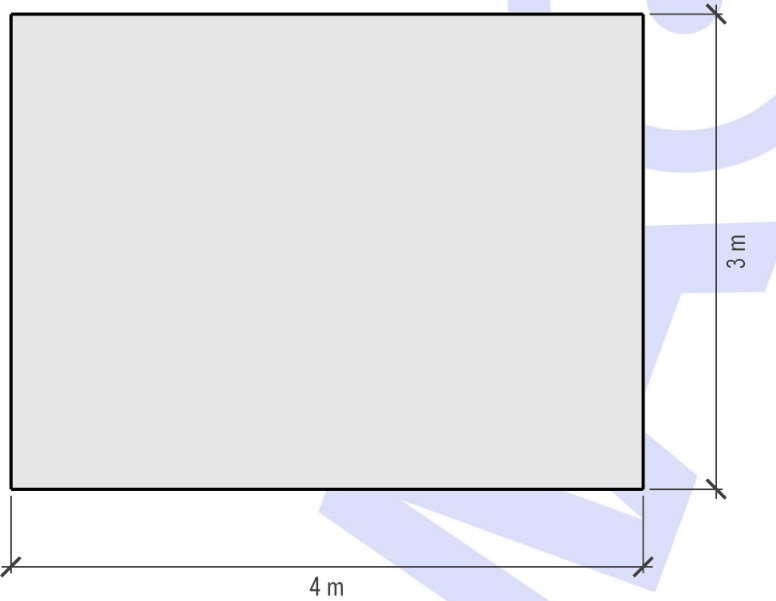

2. What is the area of the triangle?

Answer

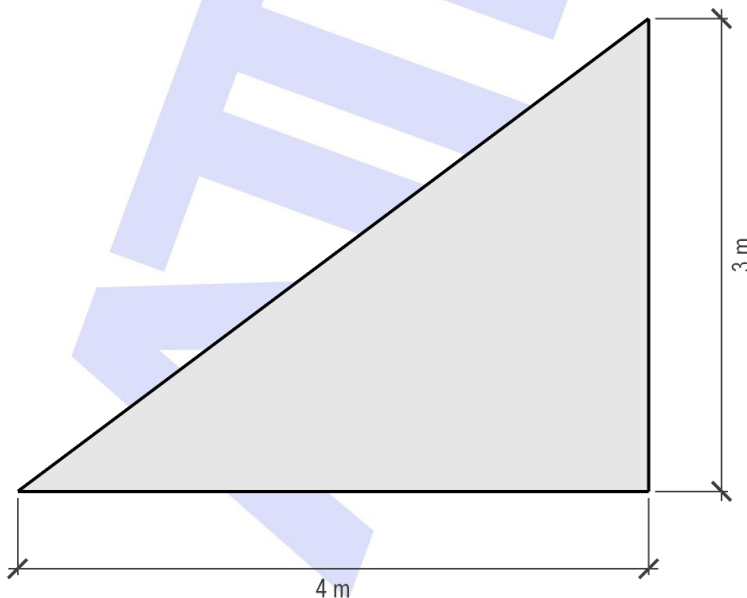

3. What is the area of this shape?

Answer

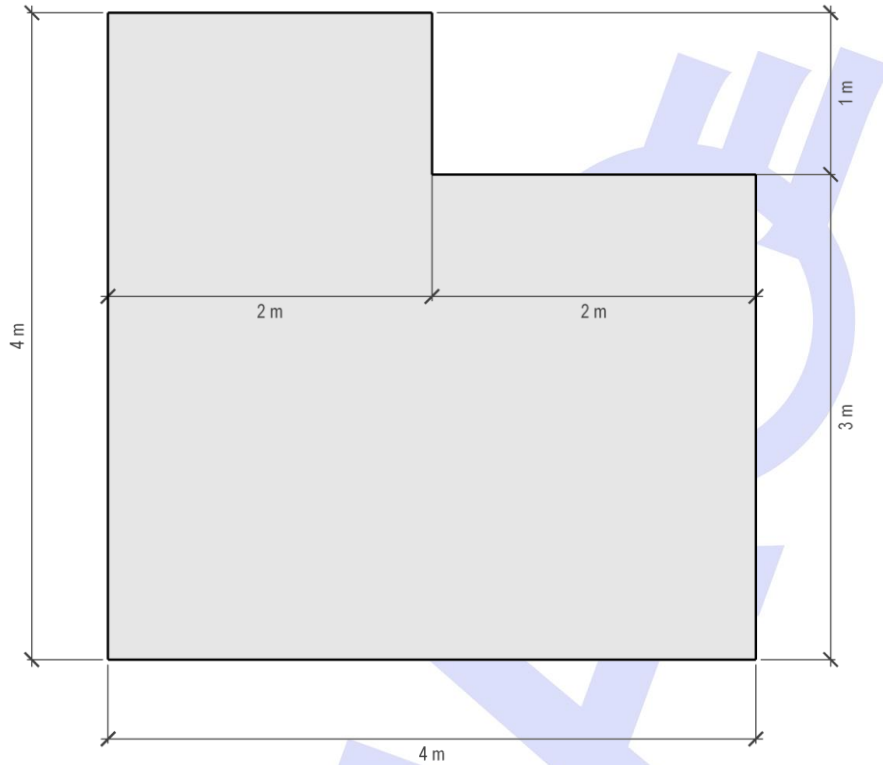

4. What is the length of the perimeter of the square?

Answer

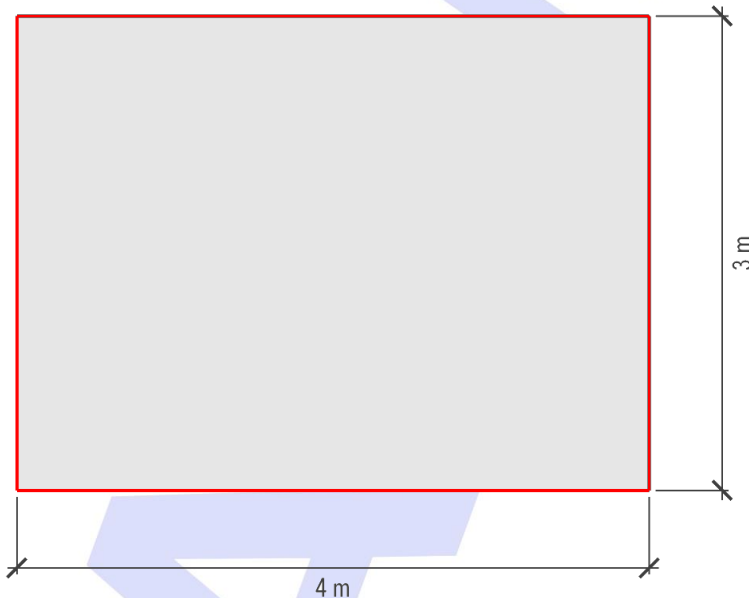

5. What is the length of the perimeter of the triangle?

Answer

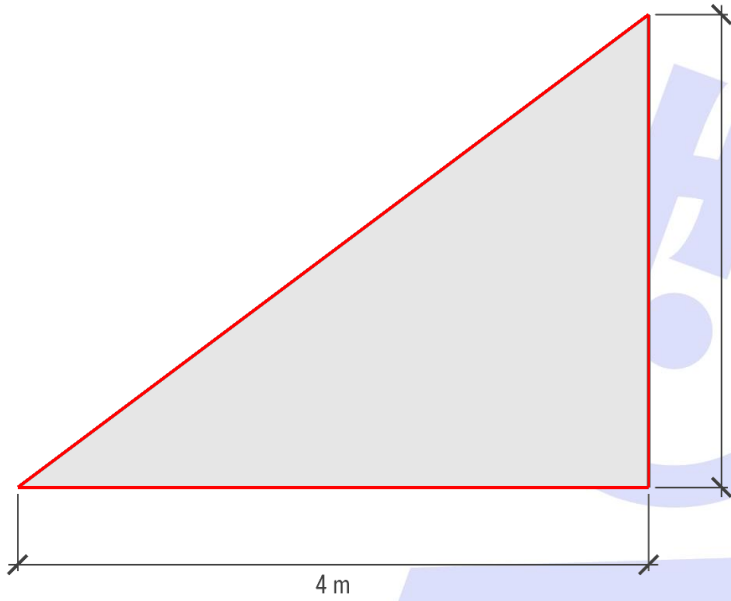

6. What is the length of the perimeter of this shape?

Answer

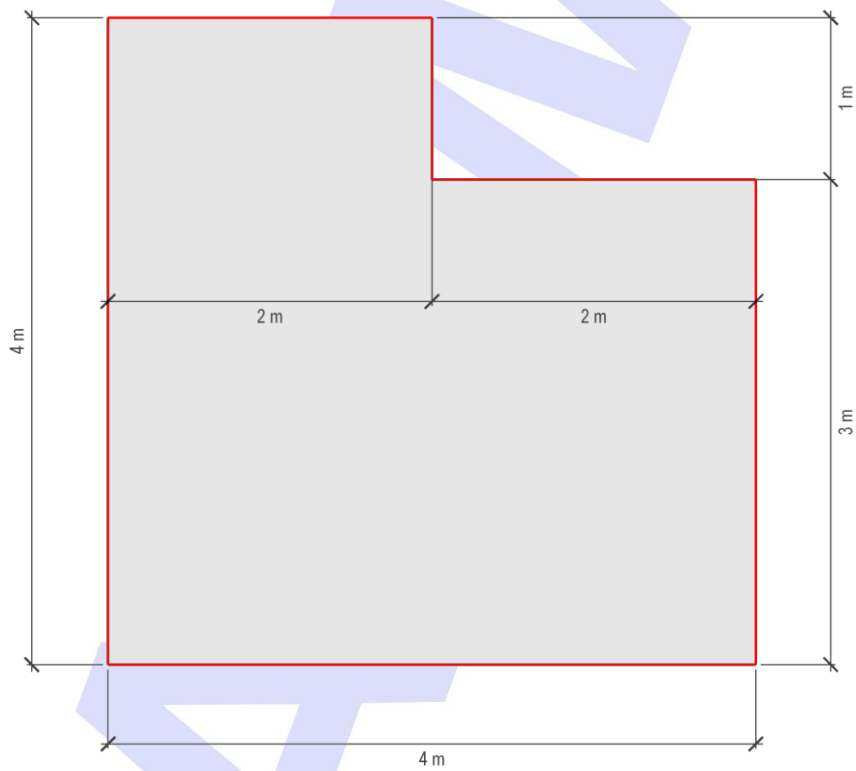

7. What is the surface area of this object?

Answer

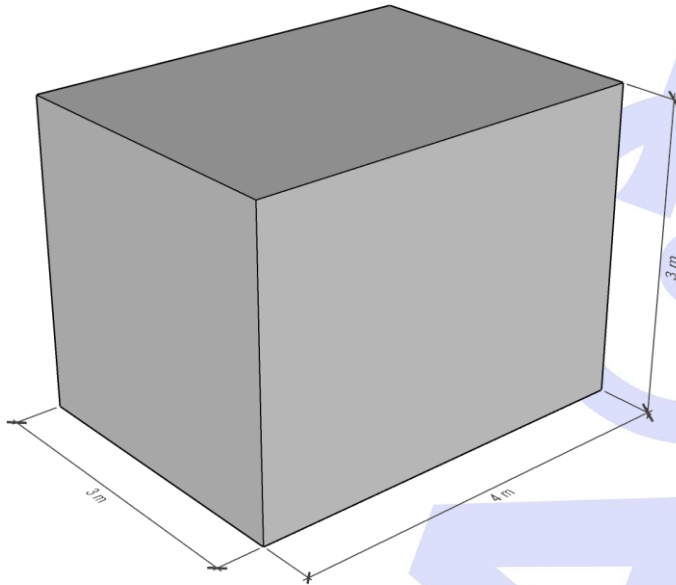

8. What is the surface area of this object?

Answer

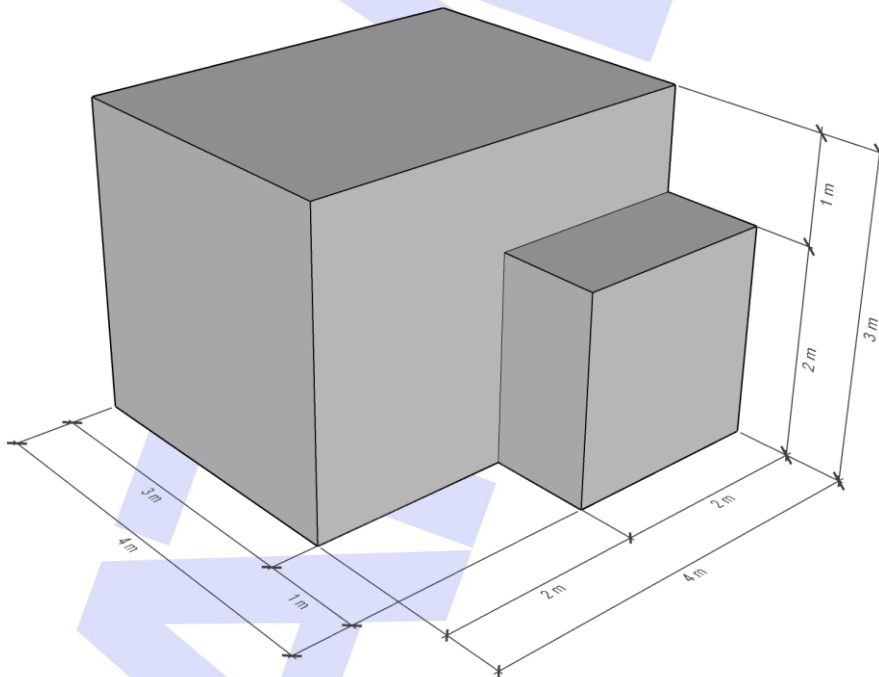

9. What is the volume of this object?

Answer

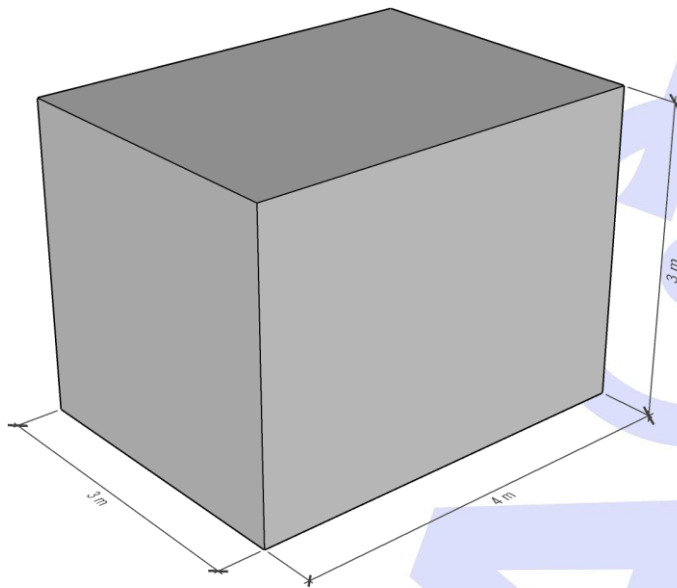

10. What is the volume of this object?

Answer

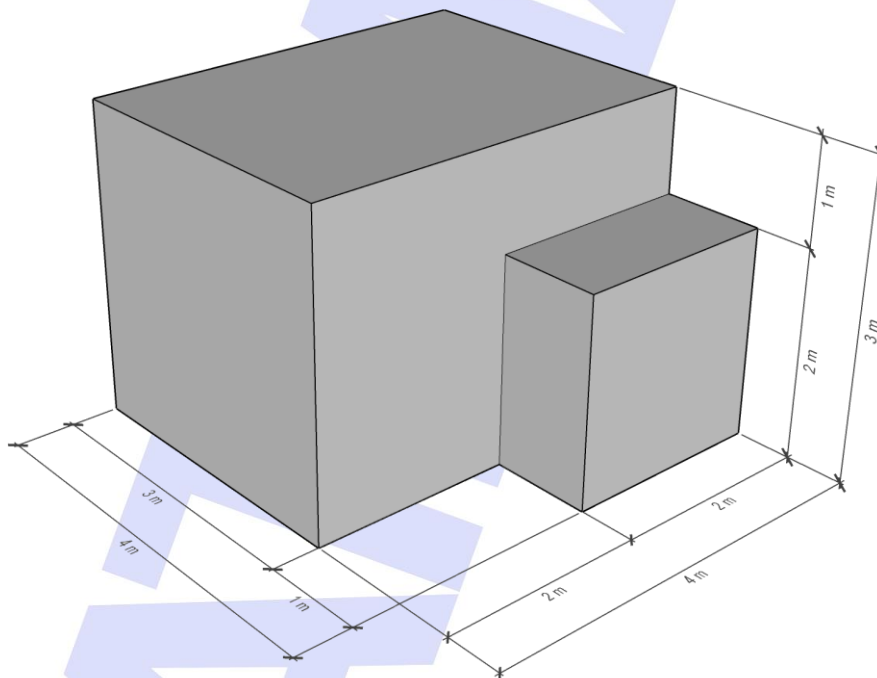

**Answers**

- 1 12m<sup>2</sup>
- 2 6m<sup>2</sup>
- 3 14m<sup>2</sup>
- 4 14m
- 5 12m
- 6 16m
- 7 66m<sup>2</sup>
- 8 74m<sup>2</sup>
- 9 36m<sup>3</sup>
- 10 40m<sup>3</sup>

